

Window Handle

for PVCu casement windows

Tools required:

Screwdriver, Hacksaw

Caution

This handle is supplied with a 40mm spindle which will need to be cut to size. Please check that the dimension between the screw holes (diagram A) mirror your current handle to ensure a correct fit.

Before you begin

The handle has been pre-fitted with a 40mm long spindle (diagram A). Measure the length of the existing spindle on the current handle, then cut this spindle to the required length.

Fitting Instructions (diagram B)

You will require a screwdriver. Place the handle in position. Insert the spindle into the drive mechanism; insert fixing screw into top screw hole. Open handle 90° to reveal bottom screw hole and insert screw. Take care not to over tighten the screws. Push the screw cover into the top screw hole. Close handle to re-engage locking mechanism. Check operation.

Cleaning

Handles should be cleaned with a soft, dry cloth. If further cleaning is required we recommend a mild solution of warm, soapy water on a soft cloth. Dry thoroughly afterwards.

Includes: window key, screws and cover caps

Please note: this product is only suitable for window locks operated by a handle with a spindle

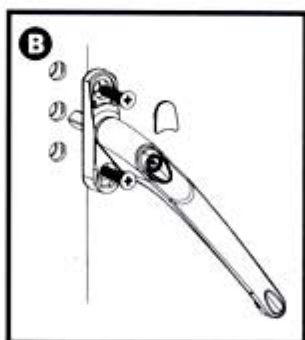
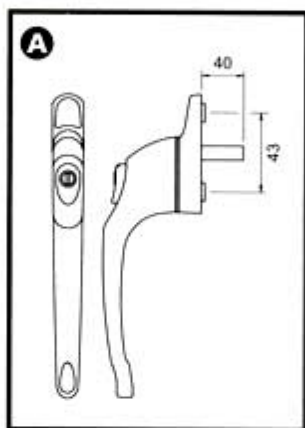

All figures are approximate